



GCL-P6/72

HIGH EFFICIENCY
MULTICRYSTALLINE MODULE

GCL-P6/72 310-330 Watt

330^W

MAXIMUM POWER OUTPUT

17.0%

MAXIMUM MODULE EFFICIENCY

0~+5^W

POWER OUTPUT GUARANTEE

Trust GCL to Deliver Reliable Performance Over Time

- World-class manufacturer of crystalline silicon photovoltaic modules
- Fully automatic facility and world-class technology
- Rigorous quality control to meet the highest standard:
ISO9001:2008, ISO 14001: 2004 and OHSAS: 18001 2007
- Tested for harsh environments (salt mist, ammonia corrosion and sand blowing test: IEC 61701, IEC 62716, DIN EN 60068-2- 68)
- Long term reliability tests
- 2*100% EL inspection ensuring defect-free modules

LINEAR PERFORMANCE WARRANTY

10 Years Product Warranty 25 Years Linear Power Warranty

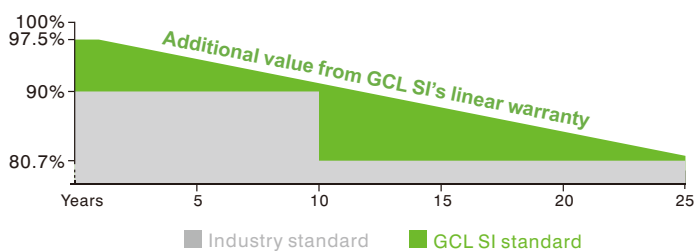

Ideal choice for large scale ground installation



High conversion efficiency due to top quality wafer and advanced cell technology



Selected encapsulating material and stringent production process control ensure product highly PID resistant and snail trails free



Passed sand blowing test, salt mist test and ammonia test; flexible for harsh environments



Optimized system performance by module level current sorting



Special cell process ensures great performance in low irradiance environment



Additional yield and easy maintenance with high transparent self-cleaning glass

Additional insurance backed by Swiss RE



According to UL 1703



Bringing Green Power to Life

GCL-P6/72

HIGH EFFICIENCY MULTICRYSTALLINE MODULE

ELECTRICAL SPECIFICATION (STC)

TYPE (STC)	GCL-P6/72 310	GCL-P6/72 315	GCL-P6/72 320	GCL-P6/72 325	GCL-P6/72 330
Maximum Power P_{max} (W)	310	315	320	325	330
Maximum Power Voltage V_m (V)	37	37.2	37.4	37.6	37.8
Maximum Power Current I_m (A)	8.38	8.47	8.56	8.64	8.73
Open Circuit Voltage V_{oc} (V)	8.99	9.08	9.17	9.24	9.33
Short Circuit Current I_{sc} (A)	45.4	45.6	45.8	46	46.2
Module Efficiency (%)	16.0	16.2	16.5	16.7	17.0
Power Output Tolerance P_m (W)	0~+5				

Values at Standard Test Conditions STC (Air Mass AM1.5, Irradiance 1000W/m², Cell Temperature 25°C).

ELECTRICAL DATA (NOCT)

Maximum Power P_{max} (W)	224.45	227.14	231.2	234.61	237.71
Maximum Power Voltage V_m (V)	33.6	33.8	34.1	34.3	34.5
Maximum Power Current I_m (A)	6.68	6.72	6.78	6.84	6.89
Open Circuit Voltage V_{oc} (V)	7.19	7.30	7.38	7.46	7.58
Short Circuit Current I_{sc} (A)	42.2	42.4	42.5	42.7	42.9

NOCT: Irradiance at 800W/m², Ambient Temperature 20°C, Wind Speed 1m/s.

MECHANICAL DATA

Solar Cells	Poly 156×156mm (6 inches)
Cell Orientation	72 Cells (6×12)
Module Dimensions	1956×992×40mm (77 × 39.05 × 1.57 inches)
Weight	22.5kg/26kg
Glass	High transparency solar glass 3.2mm (0.13 inches) or 4mm (0.16 inches)
Backsheet	White
Frame	Silver, anodized aluminium alloy
J-Box	IP67 Rated
Cables	4.0mm ² (0.006 inches ²), 1200mm (47.2 inches)
Connector	Original MC4 or Compatible
Wind Load/ Snow Load	2400Pa/5400Pa*

*For more details please check the installation manual of GCLSI

TEMPERATURE RATINGS

Nominal Operating Cell Temperature (NOCT)	45 ± 2°C
Temperature Coefficient of P_{max}	-0.41%/°C
Temperature Coefficient of V_{oc}	-0.32%/°C
Temperature Coefficient of I_{sc}	+0.055%/°C

MAXIMUM RATINGS

Operational Temperature	-40~+85°C
Maximum System Voltage	1000V DC (IEC)
Max Series Fuse Rating	15A

WARRANTY

- 10 years Product Workmanship Warranty
- 25 years Linear Power Warranty

(Please refer to GCL standard warranty for details)

PACKAGING CONFIGURATION

- Modules per box: 26 pieces
- Modules per 40'HD container: 624pieces

MODULE DIMENSION

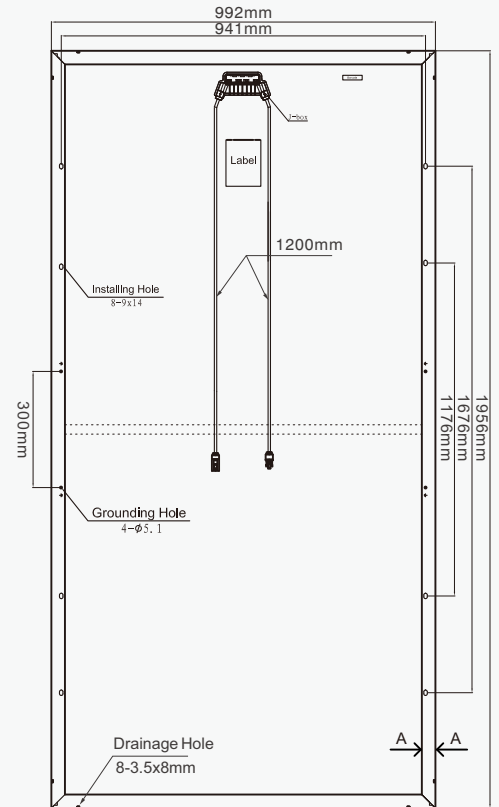

Back View

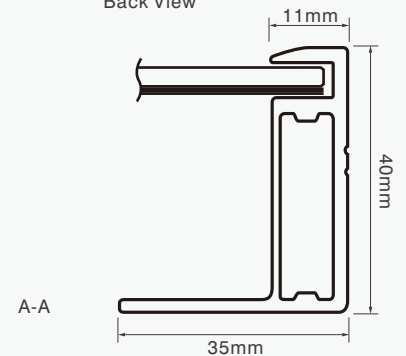

I-V CURVES OF MODULE(330W)

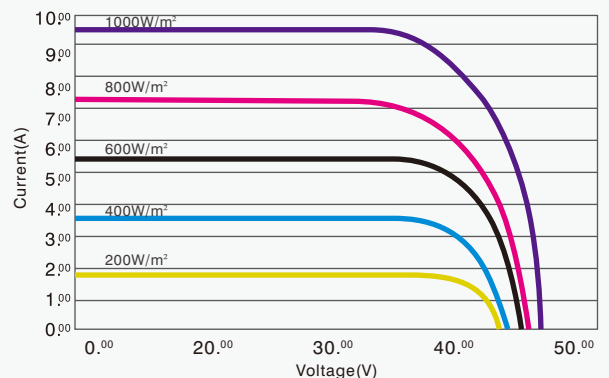

Excellent performance under weak light conditions: at an irradiance intensity of 200W/m² W/m (AM 1.5, 25 °C), 96.5% or higher of the STC efficiency (1000 W/m²) is achieved



Bringing Green Power to Life

<http://en.gclsi.com>

GCL-EN-P6/72-2016-V2.0

CAUTION: READ INSTALLATION MANUAL BEFORE USING THE PRODUCT

©2016 GCL System Intergration Technology Co., Ltd. All rights reserved. Specifications included in this datasheet are subject to change without notice.